

REMOVAL

1. **DISCHARGE FUEL SYSTEM PRESSURE**
(See page [FU-1](#))
2. **DRAIN ENGINE COOLANT** (See page [CO-3](#))
3. **DRAIN ENGINE OIL** (See page [LU-4](#))
4. **REMOVE ENGINE ASSEMBLY**
(See page [EM-186](#))
5. **REMOVE TIMING CHAIN OR BELT COVER SUB-ASSEMBLY**
(See page [LU-34](#))
6. **REMOVE CHAIN SUB-ASSEMBLY**
(See page [EM-44](#))
7. **REMOVE NO.1 COOL AIR INLET**
(a) Remove the 2 bolts, then remove the cool air inlet.
8. **REMOVE FRONT NO.2 EXHAUST PIPE ASSEMBLY**
(See page [EX-3](#))
9. **REMOVE MANIFOLD STAY**
(a) Remove the 3 bolts, then remove the exhaust manifold stay.
10. **REMOVE EXHAUST MANIFOLD SUB-ASSEMBLY LH**
(a) Disconnect the air fuel ratio sensor connector.
(b) Remove the 6 nuts, then remove the exhaust manifold and gasket.
11. **REMOVE INTAKE MANIFOLD** (See page [EM-93](#))
12. **REMOVE WATER BY-PASS JOINT RR** (See page [EM-93](#))
13. **REMOVE NO.1 CHAIN VIBRATION DAMPER**
(a) Remove the 2 bolts, then remove the chain vibration damper No. 1.
14. **REMOVE CAMSHAFT TIMING GEARS AND NO.2 CHAIN (for Bank 2)**
(a) While pushing down the chain tensioner No. 2, insert a pin of ϕ 10. mm (0.039 in.) into the hole to fix it.

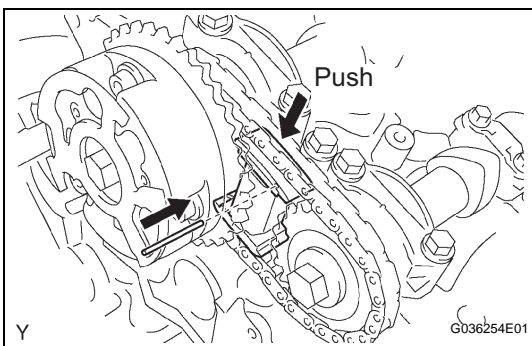

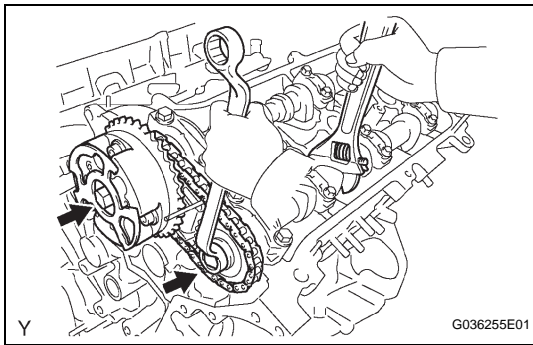

- (b) Hold the hexagonal portion of the camshaft with a wrench.
NOTICE:
Be careful not to damage the cylinder head and valve lifter with the wrench.

- (c) Remove the 2 bolts, then remove the camshaft timing gear, camshaft timing gear assembly and timing chain No. 2.

NOTICE:
Do not disassemble the camshaft timing gear assembly.

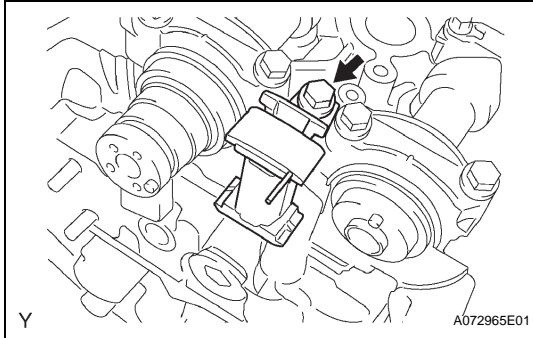

15. REMOVE NO.2 CHAIN TENSIONER ASSEMBLY

- (a) Remove the bolt, then remove the chain tensioner No. 3.

16. REMOVE CAMSHAFTS

NOTICE:
Keep the camshaft level while it is being removed. The camshaft thrust clearance is very small and failing to keep it level could crack or damage the cylinder head journal surface, which receives the thrust. This could subsequently lead the camshaft to seize or break. Perform the following steps to avoid such problems.

- (a) Using several steps, uniformly loosen and remove the 16 bearing cap bolts in the sequence shown in the illustration.
 (b) Remove the 8 bearing caps and 2 camshafts.

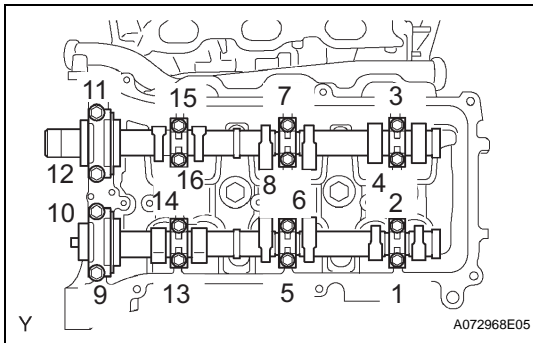

17. REMOVE CYLINDER HEAD LH

- (a) Remove the bolt, then separate the ground cable.

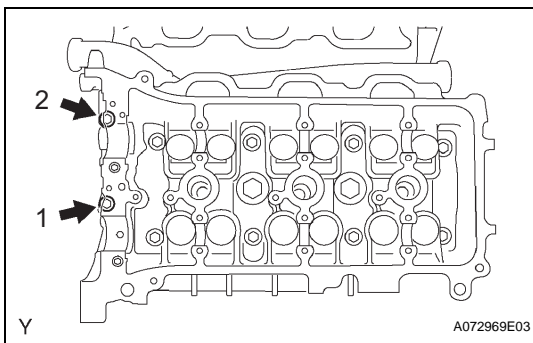

- (b) Using several steps, remove the 2 cylinder head bolts on the cylinder head in the sequence shown in the illustration.

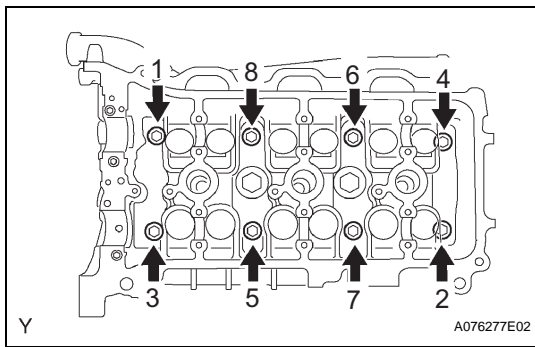

- (c) Using several steps, uniformly loosen the 8 cylinder head bolts on the cylinder head with a 10 mm bi-hexagon wrench in the sequence shown in the illustration. Remove the 8 cylinder head bolts and 8 plate washers.

NOTICE:

- Be careful not to drop the plate washers into the cylinder head.
- Cylinder head warpage or cracking could result from removing the bolts in the wrong order.

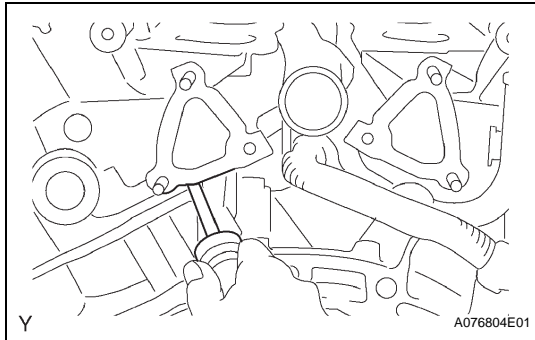

- (d) Lift the cylinder head from the dowels on the cylinder block, and place the cylinder head on wooden blocks on a bench.

NOTICE:

- Be careful not to drop the plate washers into the cylinder head.

If the cylinder head is difficult to remove, pry between the cylinder head and cylinder block with a screwdriver.

18. REMOVE NO.2 CYLINDER HEAD GASKET INSPECTION

1. INSPECT CYLINDER HEAD SET BOLT

- (a) Using vernier calipers, measure the outside diameter of the bolt thread.

Standard outside diameter:

10.85 to 11.00 mm (0.4272 to 0.4331 in.)

Minimum outside diameter:

10.7 mm (0.421 in.)

