

# Wireless Door Lock Control

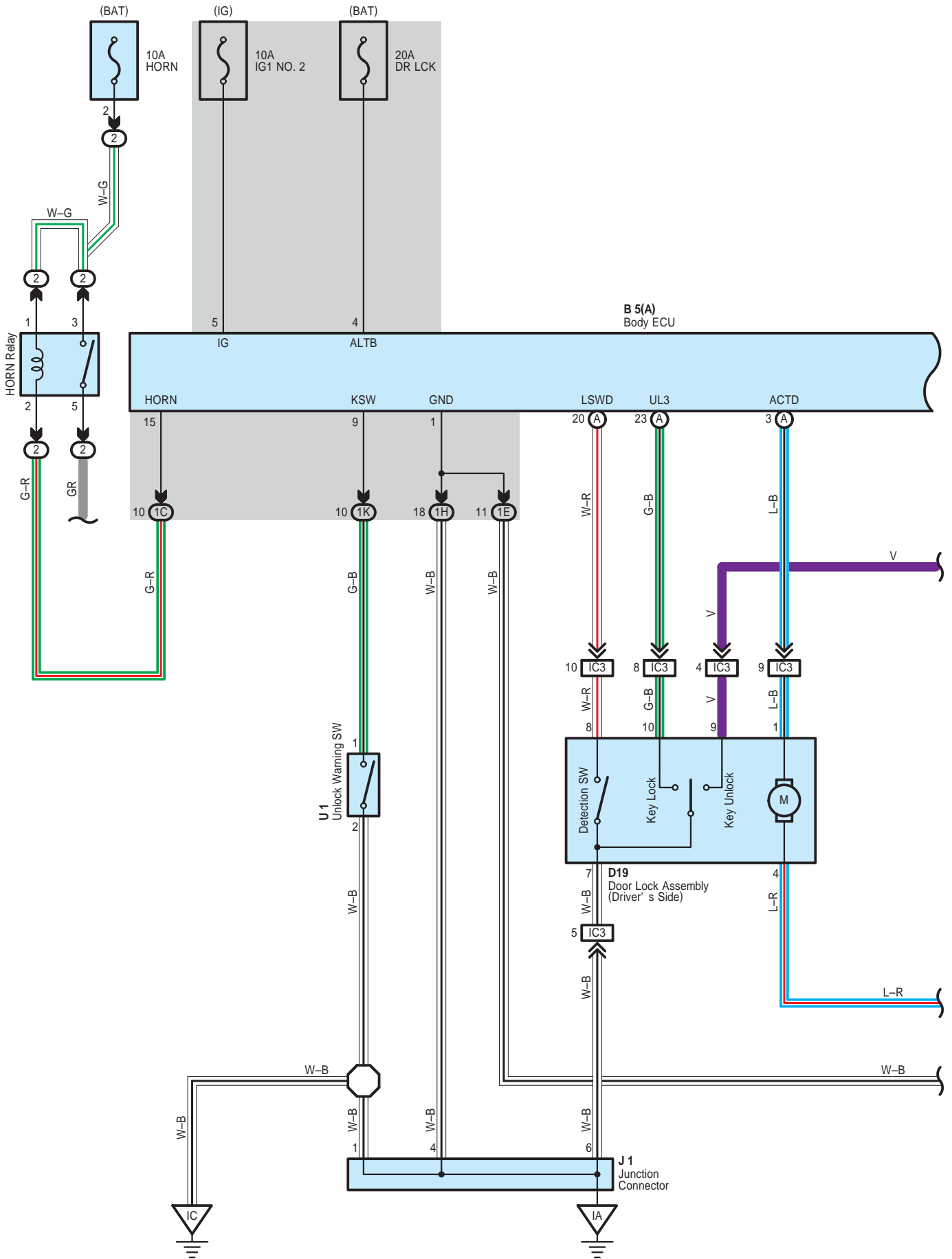

\* 1 : Double Cab  
 \* 2 : Access Cab

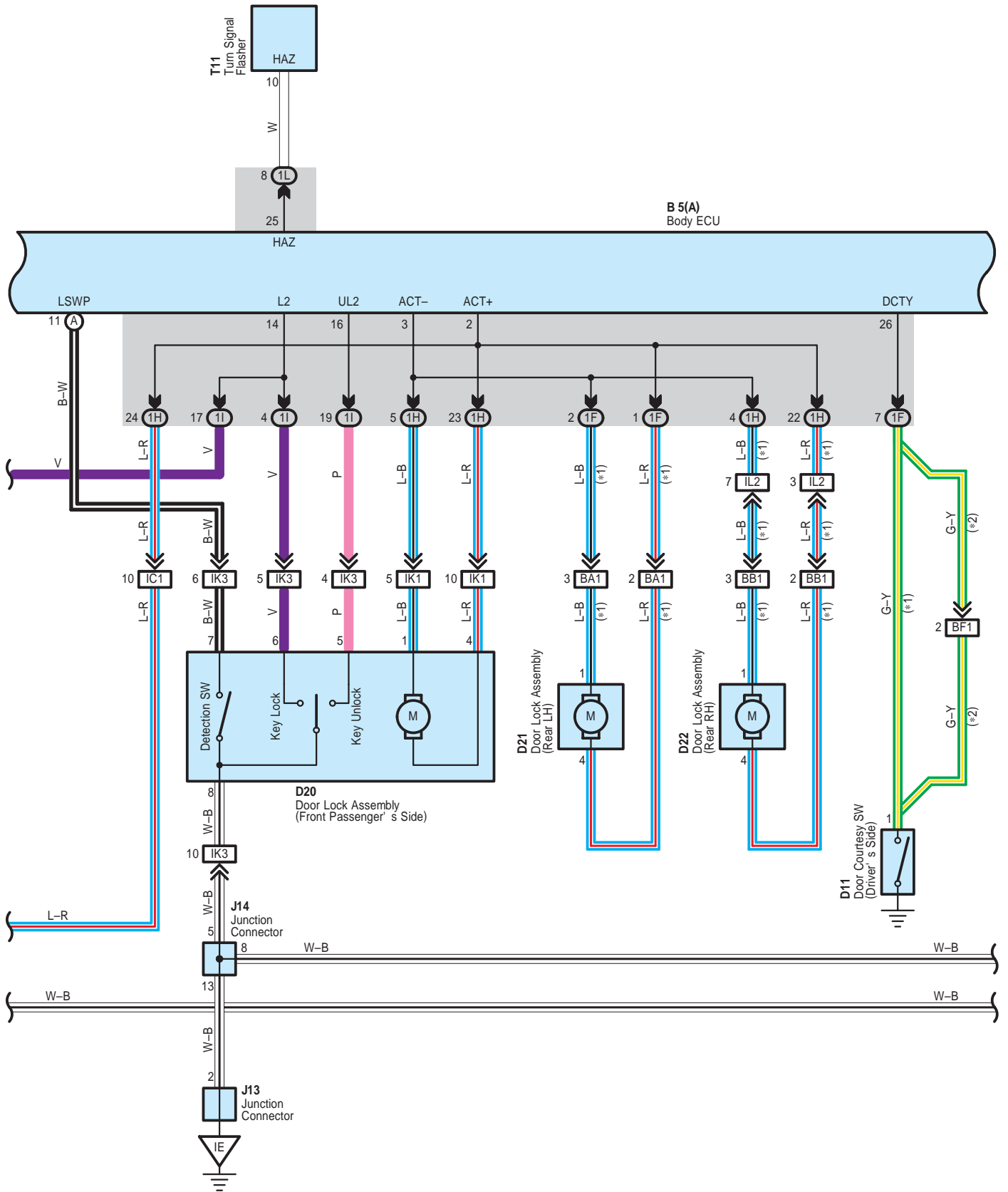

# Wireless Door Lock Control

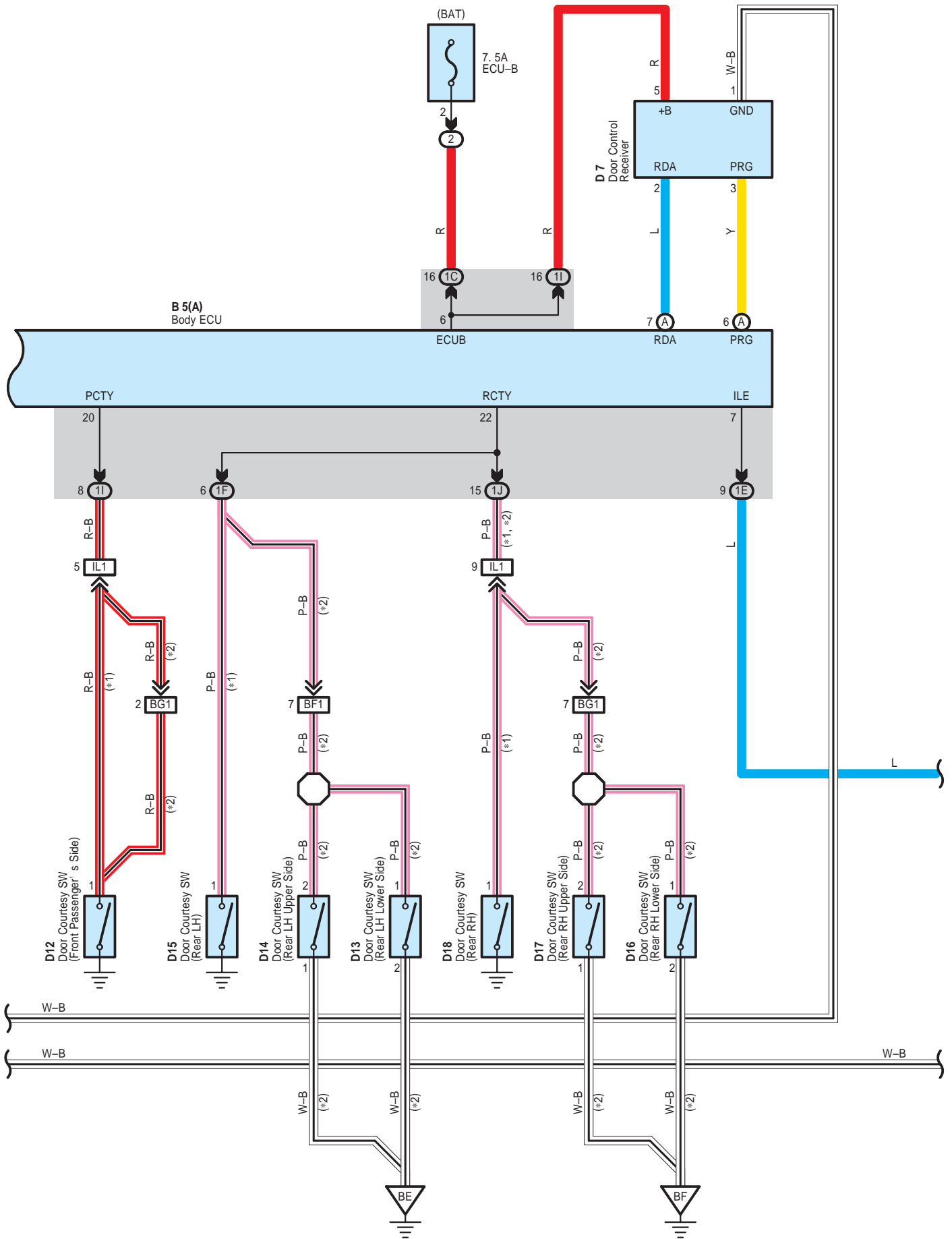

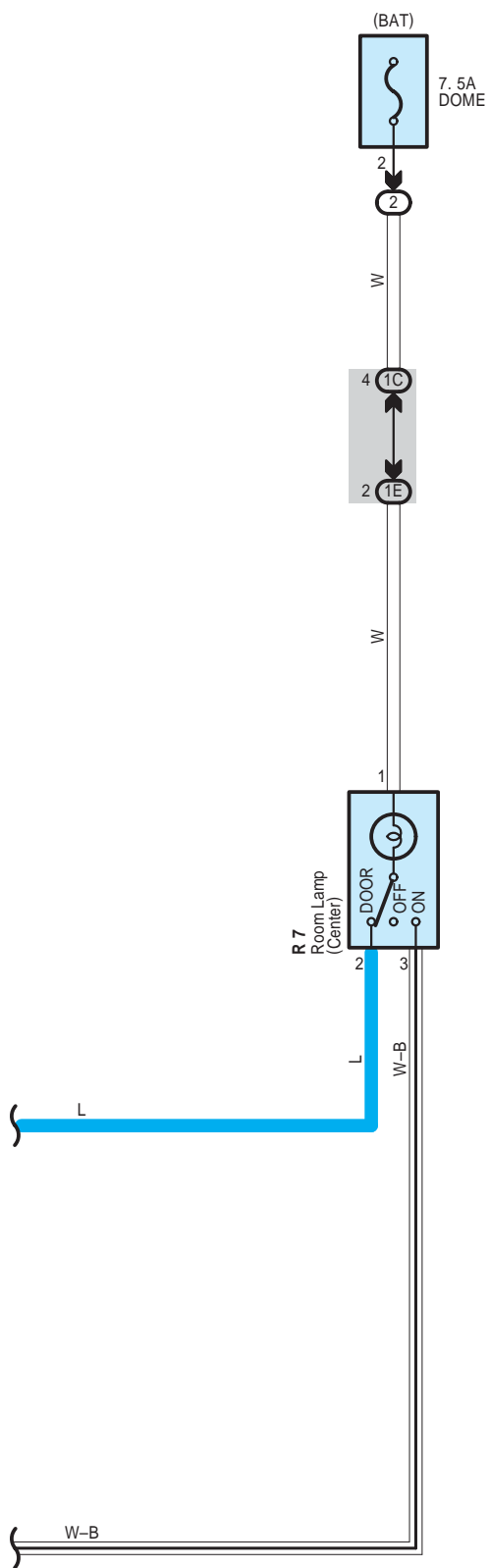

\* 1 : Double Cab  
 \* 2 : Access Cab

# Wireless Door Lock Control

## System Outline

Door lock control (Lock and unlock) and panic control (Theft alarm and flash) is performed by remote control, without the ignition key inserted in the door key cylinder, using low-power electrical waves emitted by a transmitter.

### 1. Normal Operation

#### \* Lock operation

When the lock SW on the transmitter is pressed, all the doors are locked.

#### \* Unlock operation

When the unlock SW on the transmitter is pressed once, only the driver door is unlocked. When the unlock SW is pressed again within 3 seconds, all the doors are unlocked.

### 2. Auto Lock Function

When the door is not actually opened within 30 seconds after the door has been unlocked by the unlock SW on the transmitter, all the doors are automatically locked. If any of the following conditions are detected, the wireless door lock does not function.

#### \* Any door is opened.

#### \* The ignition key is inserted into the ignition SW.

#### \* When the lock detection SW of all the doors are locked.

### 3. Wireless Door Lock Stop Function

If any of the following conditions are detected, the wireless door lock does not function.

Lock operation

#### \* When any door is open (Door courtesy SW on)

#### \* The ignition key is inserted into the ignition SW (Unlock warning SW on)

#### \* Ignition SW is on

Unlock operation

#### \* Ignition SW is on

### 4. Visual Confirmation of Lock or Unlock

During lock operation, when the body ECU receives a lock signal from the door lock detection SW, the turn signal light is flashed once. During unlock operation, when the body ECU receives an unlock signal from the door lock detection SW, the turn signal light is flashed twice.

### 5. Remote Panic Operation

Panic will function when doors are locked or unlocked, open or closed. When the panic button (Transmitter) is pushed once, interior lights light up, and theft alarm and horn sounds and turn signal light, headlights and taillight flash. Then, the panic or the unlock button (Transmitter) is pushed once more, interior lights are turned off, sounding and flashing will stop. Panic will not function when ignition key is in ignition key cylinder.

### 6. Repeat Function

If the lock detection signal in response to the output signal is not received after the body ECU has output the lock signal, the lock signal is output again.

### 7. Illuminated Entry Function

When the body ECU detects the unlock state after the unlock operation has been made, it turns on the lights, such as the interior light for approx. 15 sec. If all the doors are locked during this operation, lighting is cancelled and the lights immediately fade out.

## ○ : Parts Location

Code	See Page	Code	See Page	Code	See Page
B5	A	44		D16	48 (*2)
				J1	45
D7		44		D17	48 (*2)
				J13	45
D11		46 (*1)		D18	46 (*1)
		48 (*2)		J14	45
D12		46 (*1)		D19	46 (*1)
		48 (*2)			R7
D13		48 (*2)		D20	48 (*2)
		46 (*1)			T11
D14		48 (*2)		U1	45
D15		46 (*1)		D21	46 (*1)
				D22	46 (*1)

\* 1 : Double Cab   \* 2 : Access Cab   \* 3 : Regular Cab   \* 4 : Separate Seat   \* 5 : Bench Seat

 : Relay Blocks

Code	See Page	Relay Blocks (Relay Block Location)
2	24	Engine Room R/B (Engine Compartment Left)

 : Junction Block and Wire Harness Connector

Code	See Page	Junction Block and Wire Harness (Connector Location)
1C	28	Engine Room Main Wire and Driver Side J/B (Lower Finish Panel)
1E	28	Roof Wire and Driver Side J/B (Lower Finish Panel)
1F	28	Floor No.2 Wire and Driver Side J/B (Lower Finish Panel)
1H	29	Instrument Panel Wire and Driver Side J/B (Lower Finish Panel)
1I		
1J		
1K		
1L	29	Relay Wire and Driver Side J/B (Lower Finish Panel)

 : Connector Joining Wire Harness and Wire Harness

Code	See Page	Joining Wire Harness and Wire Harness (Connector Location)
IC1	54	Front Door LH Wire and Instrument Panel Wire (Left Kick Panel)
IC3		
IK1	55	Front Door RH Wire and Instrument Panel Wire (Right Kick Panel)
IK3		
IL1	55	Instrument Panel Wire and Floor Wire (Right Kick Panel)
IL2		
BA1	56 (*1)	Rear Door No.2 Wire and Floor No.2 Wire (Under the Left Center Pillar)
BB1	56 (*1)	Rear Door No.1 Wire and Floor Wire (Under the Right Center Pillar)
BF1	57 (*2)	Rear Door No.2 Wire and Floor No.2 Wire (Under the Left Quarter Panel)
BG1	57 (*2)	Rear Door No.1 Wire and Floor Wire (Under the Right Quarter Panel)

 : Ground Points

Code	See Page	Ground Points Location
IA	54	Left Kick Panel
IC	54	Instrument Panel Brace RH
IE	54	Right Kick Panel
BE	57 (*2)	Inside of the Access Door LH
BF	57 (*2)	Inside of the Access Door RH

\* 1 : Double Cab    \* 2 : Access Cab    \* 3 : Regular Cab    \* 4 : Separate Seat    \* 5 : Bench Seat